



Screen Kit Installation Manual

2. BEFORE YOU BEGIN INSTALLING
3. INSTALLATION FOR MULTIPLE ROOMS
4. PUMP & MANIFOLD ASSEMBLY
6. ELECTRICAL SETUP
9. TYPICAL FIXING METHODS

SCREED KIT OVERVIEW

Screed Kits require the underfloor heating pipe to be fixed to a foil backed insulation board then covered by a screed, so are best suited for new builds and extensions where a new floor slab will be laid. Screed Kits are not suitable for retro fitting onto existing floors or over joists, for these types of projects please view our range of Overlay Kits and Joist Kits.



BEFORE YOU BEGIN

Please read through these instructions carefully and check that you have all the components required. Your water underfloor heating kits contain everything you need in one box for your water underfloor heating project. NB: This multi zone system is controlled by multiple thermostats.

- **A rated Wilo or Grundfos pump**
- **PE-RT-multilayer pipe to suit area**
- **Edging insulation (NA: for low profile)**
- **Thermostat**
- **Actuators**
- **Pipe Staples**
- **Pipe Cutter**
- **Wiring centre**
- **All pipe connections to fix pipe to pump and manifold**

We use **high quality multi layered pipe** (PE-RT AL PE-RT) in all our water underfloor heating systems

AN INNER LAYER in cross-linked polyethylene PE-RT (crosslinked with silanes)

AN INTERMEDIATE LAYER in aluminium alloy, butt-welded along length of pipe.



PIPE WARRANTY

- ✓ PE-RT AL PE-RT
- ✓ Working pressure & temperature 6bar, 70°C
- ✓ 100% oxygen impermeable
- ✓ Lifetime warranty

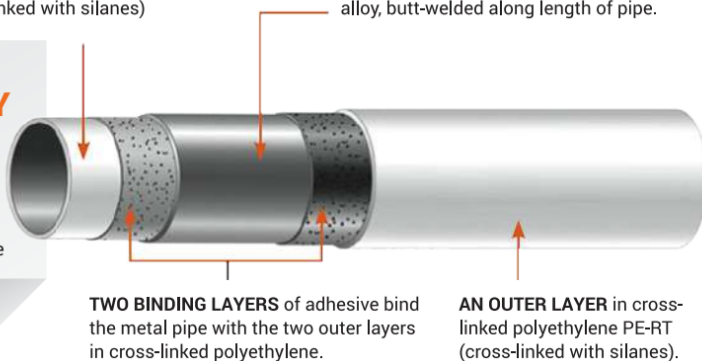

Installation for a Multiple Room (multi circuit system)

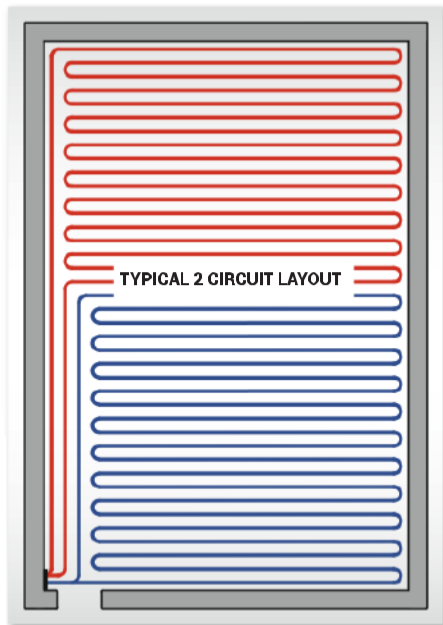
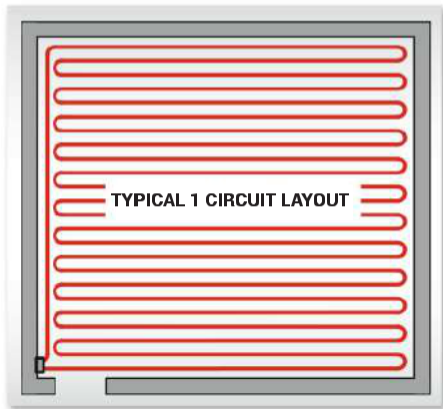

1. Select a suitable location for the pump and manifold unit and mount on the wall. See next page for assembly.
2. Refer to the typical pipe installation drawings and determine the pipe layout - the layout is not critical and can be varied to suit site conditions, the important criteria being the pipe spacing, see below.
3. The pipe is marked every metre by the metre, (maximum length for any circuit is 100m, 60m for low profile 12mm pipe circuit).
4. Pipes should be laid 100mm away from walls.
5. Do not lay pipe under fixed units.
6. Lay the rooms furthest from the manifold and work back, do the room with the manifold last.
7. When pipes to/from one area pass through another area, the two pipes should be run together, the 'bunches' of pipes should then be spaced as if they were one pipe.
8. Lay the pipe as planned, fixing every 50cm if on a screeded celotex base and return to the manifold.
9. If the pipe is kinked when bending, the pipe should be straightened and rearranged so that the location of the kink remains in a straight length, no other remedial action is required.

LOW PROFILE SYSTEM panels are spaced at 150mm centres.

STANDARD OUTPUT SYSTEM suitable for internal well insulated areas such as living room, kitchen or bathroom. Pipe spacings are set at 200mm centres

HIGH OUTPUT SYSTEM suitable for areas of high heat loss, ideal for conservatories, extensions and external buildings.

Pipe spacings are set at 150mm centres.

- To lay the circuit, cut the pipe end squarely using the plastic pipe cutter, re-round the pipe end with the tool provided, place the nut over the pipe, ensure the olive and insert is fully fitted over the end of the pipe and the assembly is attached to the manifold. Tighten the nut using an open end spanner. Do not over tighten.

- Note also the room to which each circuit applies.
- Prevent people from walking on the pipes, keep tools etc away from the pipes and use running boards. The pipe is very tough, but it is better to be safe than sorry.

PUMP & MANIFOLD ASSEMBLY

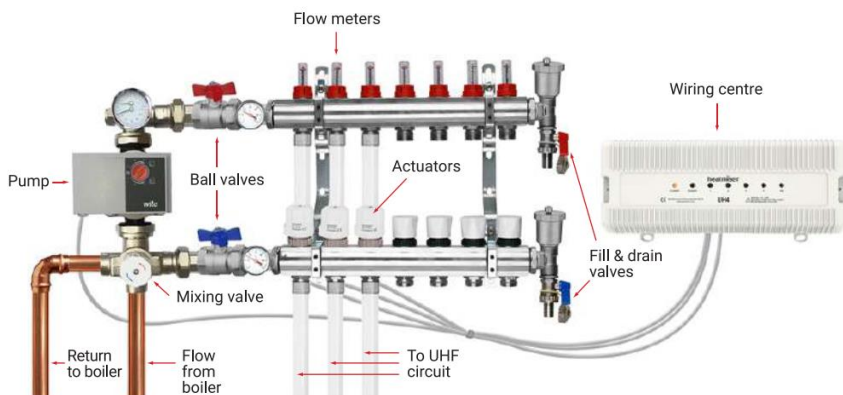

- Attach manifold to wall.
- Fit ball valves to manifold, the end with the loose nut to manifold (remember the washers!).
- Assemble pump & mixing valve as shown.
- Connect supply pipework to mixing valve using 3/4" male iron compression fittings.

DO NOT APPLY HEAT TO MIXING VALVE

FILLING THE MANIFOLD SYSTEM

- It is **IMPORTANT** that the underfloor heating system is properly filled with water and purged completely of air to ensure correct operation, it is therefore necessary to follow the procedure below.
- IT IS NOT ADEQUATE TO FILL THE SYSTEM USING THE BOILER FILLING LOOP!**
- Connect a hose from a mains pressure cold water supply to the hose connection on the top (flow) manifold, and another hose from the hose connection on the bottom (return) manifold to a drain.
- Ensure that all the white caps on the bottom (return) manifold are screwed down, closing the valves.



FILLING THE MANIFOLD SYSTEM (cont.)

5. Ensure that the main flow & return ball valves are closed on the manifold.
6. Turn on the water and open the hose connection valve on the top (flow) manifold.
7. Open the first circuit valve by unscrewing the white cap allowing water to flow into the Pipe.
8. Open the hose connection valve on the bottom (return manifold) allowing water to flow freely into the drain until the water is clear with no air bubbles.
9. Open the second circuit valve (white cap) and close the first.
10. Open the third circuit valve and close the second etc.
11. Continue until the last circuit has been purged and close the hose connection valve on the bottom (return) manifold before closing the last circuit valve (white cap).
12. While under pressure, check manifold & pipework for leakage.
13. Close hose connection valve on the top (flow manifold) and remove the hoses.

COMMISSIONING

1. Screed or chipboard flooring should be laid immediately after pipelaying to protect the pipe.
2. Concrete screed floors must be cured before any heat is applied, a general rule of thumb is to allow 1 day per 2 millimetres of screed.
3. Timber floor with drymix infill can have heat applied immediately, the drymix must be dried completely before laying the flooring.
4. Hardwood timber flooring must be 'conditioned' before fixing.
5. It is important to purge the pipework from the boiler to the manifold, to avoid air being introduced into the underfloor heating system.
 6. It is not normally necessary to balance the system but if required follow this procedure. The system is balanced by running the pump, and adjusting the flow to each zone by turning the square spigots under the white caps on the bottom manifold, the flow in the respective sight glasses should be set at a figure calculated by dividing the length of pipe for that zone by 40. Example: Circuit 1, 85m/40 = approx 2 on the scale. Low profile systems circuit at 70m/40=1.75.
7. Fit actuators to valves after connecting the control wiring.
8. It is important that the actuators are screwed tightly on to the valve.
9. Initially start the system with the thermostatic valve set at min (35°C).
10. Increase the setting by 5° per day, up to a maximum of 50° for concrete floors, max 65° for timber floors.
11. The flow & return from the boiler should be connected to the manifold connections shown using compression couplings.
12. NOTE. When first starting up the system it may take 12-24 hours for

MAINTENANCE We recommend that the following maintenance be carried out annually.

1. Check that all actuator nuts are tightened firmly and that actuators are not loose.
2. Remove end plug from pump and check that pump rotates when energised.
3. Turn up thermostats & check that actuators move into open position also check flow gauges are indicating. If not, repressurise manifold, remove indicator, clean & replace, repressurise manifold.

ELECTRICAL SETUP



1. Wiring from thermostats to manifold wiring centre should be 1 mm Score + earth (6243Y). NB: A network system must be wired in 'CAT6' cable.
2. The wiring centre has a back entry to avoid surface wiring.
3. Where one room has more than one pipe circuit it will be necessary to connect all the circuit actuators to that particular zone on the controller, controlled by one thermostat.
4. Thermostat position in the room is not critical but positions affected by the sun should be avoided, mounting height approx 1.5M

① Wiring from thermostats to manifold wiring centre should be 1mm 3core + earth(6243Y). N.B: A network system must be wired in 'CAT6' cable.

② The wiring centre has a back entry to avoid surface wiring.

③ Where one room has more than one pipe circuit it will be necessary to connect all circuit actuators to that particular zone on the controller, controlled by one thermostat.

④ Thermostat position in the room is not critical but positions affected by the sun should be avoid, mounting height approx 1.5M

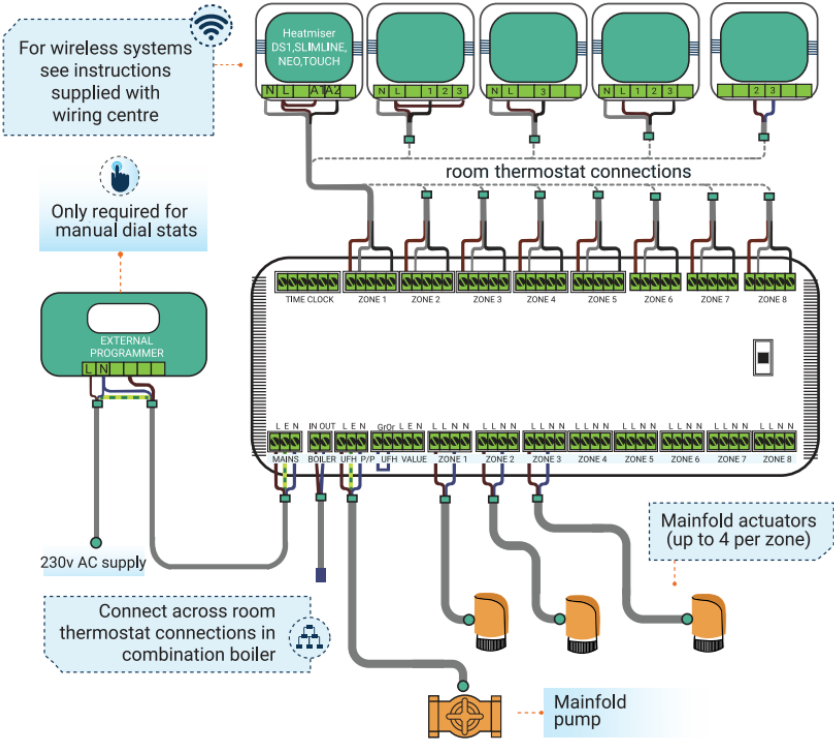

WARNING: DO NOT CONNECT 230V FROM THIS CONTROL SYSTEM TO THE BOILER TERMINALS OR BOILER MAY BE DAMAGED!

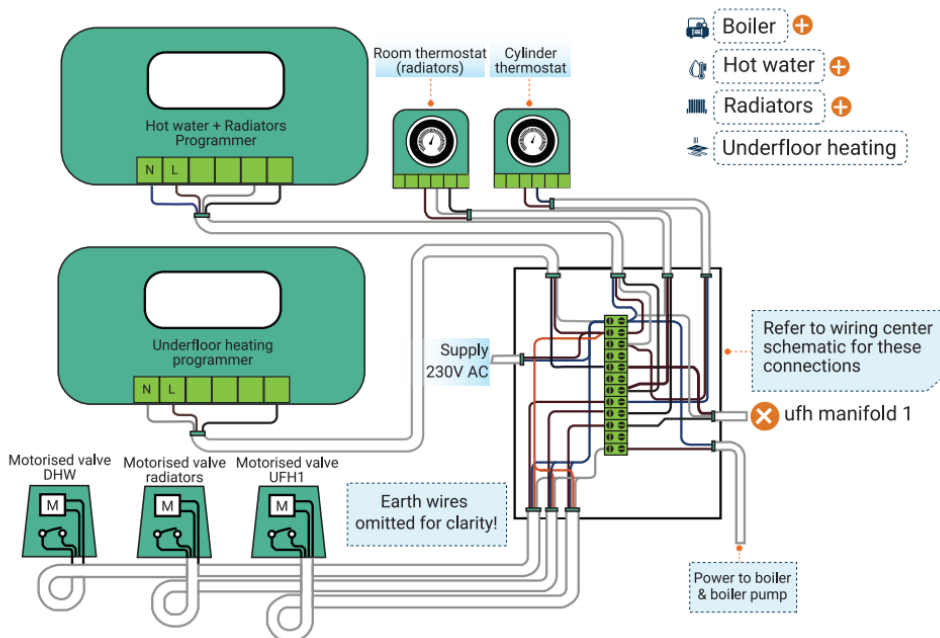
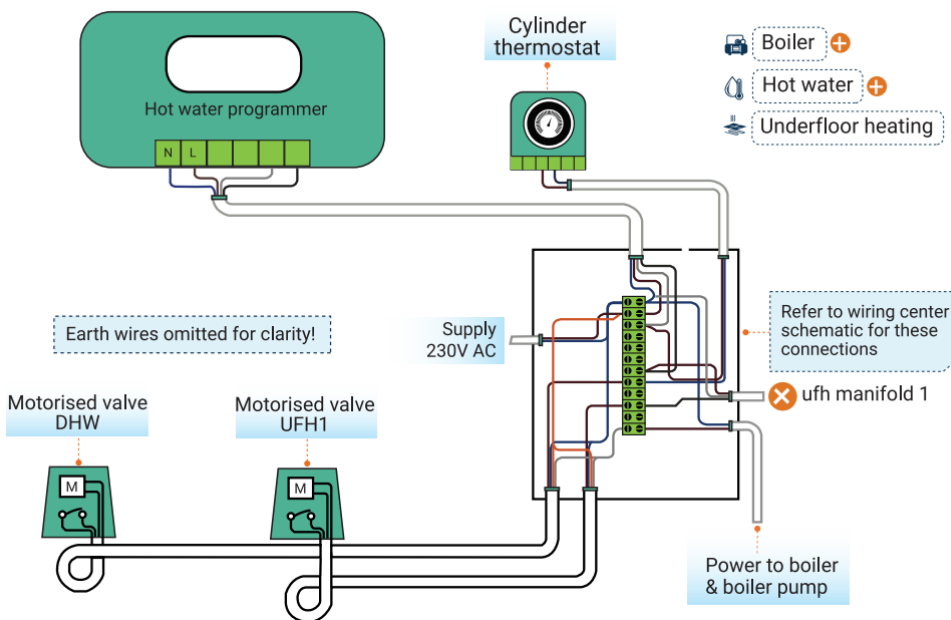

- Schematic for system boiler &
- UFH +
- Radiators +
- Hot water

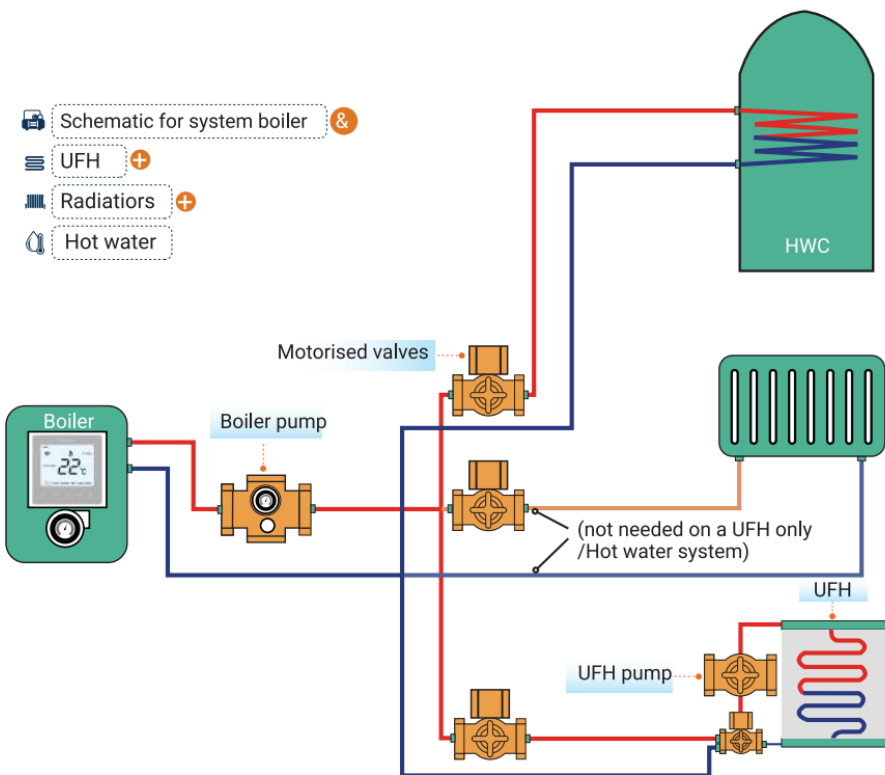

- Schematic for gas combination boiler &
- Underfloor heating +
- Radiators +

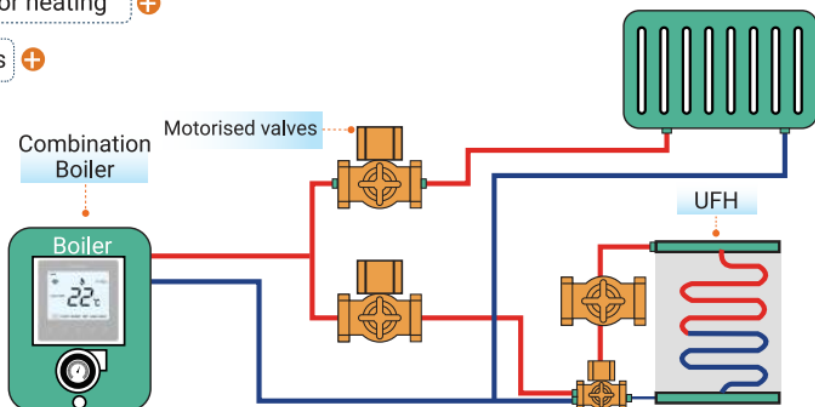

TYPICAL FIXING METHODS



UNDER NEW CONCRETE OR SCREED FLOORS

A cost effective solution for installing water underfloor heating into new build properties or new extensions.

This type of system installation is the most popular and cost effective type on the market today, the pipes are incased in screed or concrete meaning that the whole floor warms up like one huge storage radiator. This system is normally for new build houses or extensions/conservatories.

CLIP RAIL SYSTEM



BETWEEN JOISTS OR SUSPENDED FLOORS

Installing water underfloor heating between joists is easy using our different installation solutions.

Please note all in joist systems require the pipe spacing to be 200mm apart or less. This means you need to select a conservatory style kit or a multiple room kit - standard room kits are designed with the pipe spacing at 250mm centers which would mean you would not have enough pipe in the kit.

SPREADER PLATE SYSTEM



OVER EXISTING FLOORS

Installing water underfloor heating over existing floors is simple using our different installation solutions.

Our overfloor systems can be installed directly over any solid sub-floor such as existing floorboards, plywood or concrete/screed floors, or any solid surface such as existing tiles/wooden floors.

OVERLAY FLOOR PANELS



TYPICAL FIXING METHODS



PLASTIC EGG CRATE SYSTEM



CLIPPED DIRECT WITH STAPLES



IN JOIST FOIL BOARDS



Tel: 01932 784848

Email: info@rayotec.com

Rayotec Ltd, Unit 5 Trade City, Brooklands Close
Sunbury on Thames TW16 7FD